

**FILTER CAKE WASHING & AIR BLOW DOWN OF A FILTER CAKE**

Fig 1  
View of the internal  
porting arrangement

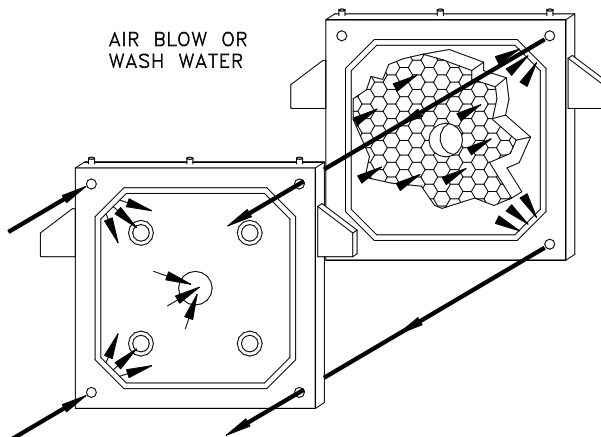
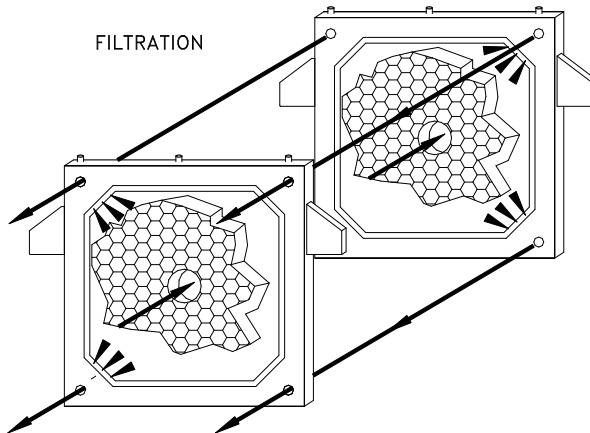
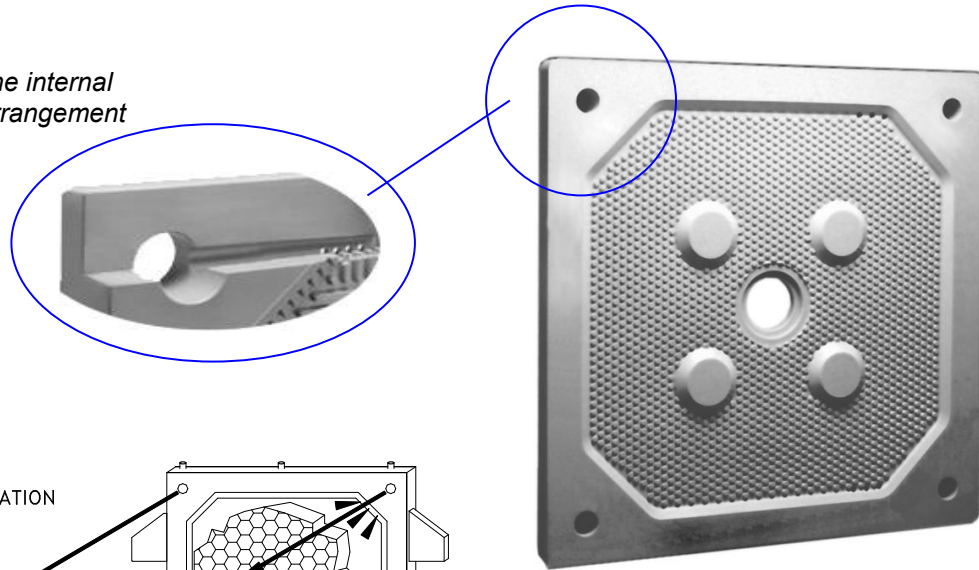

THE ROUTING FOR BOTH WASHING AND AIR BLOWING A FILTER CAKE IS ACCOMPLISHED IN THE SAME WAY.

FILTER PLATES MUST BE CLOSED DELIVERY (NOT OPEN FILTRATE) AND BE DESIGNED AS #1 AND #3 BUTTON DISCHARGE I.E. ALTERNATING CORNER PORTING. AIR OR WASH LIQUOR IS INTRODUCED INTO THE FILTER CAKE VIA THE SAME PIPING ROUTE USED FOR FILTRATE DISCHARGE.

THE DISCHARGE PIPING MANIFOLD ON THE FILTER PRESS IS DESIGNED WITH A VALVE ARRANGEMENT TO ISOLATE THE FILTRATE DISCHARGE LINE. WASH LIQUOR OR AIR ENTERS THE FILTER PLATE VIA THE PLATE CORNER PORTING SHOWN IN FIG 1. AND PASSES THROUGH THE FILTER CAKE TO THE NEXT CHAMBER WHERE IT EXITS THE CHAMBER'S OPEN PORTS.

MULTIPLE CROSS WASHING DIRECTIONS ARE POSSIBLE AND THROUGH WASHING IS ALSO EFFECTIVE (USING THE FEED PORT).